

Flange sleeves BB01

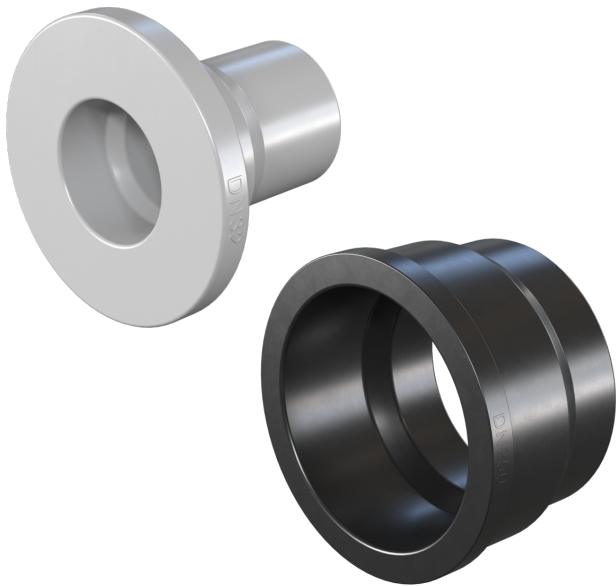

description:

Flange sleeves are used as exit aids in plastic pipeworks.

product features:

- standard pre-welding collar on the outlet side not applicable
- larger opening angle of the flap
- no longer flange screws required
- DN 32 – 300 for socket welding system

diameter:

DN 32, 40, 50, 65, 80, 100, 125, 150, 200, 250, 300

material:

PP-H and PE

standard dimension ratio*:

SDR 11 and SDR 17,6

dimensions:

DN	ØdA	Ødi		ØdiA	ØD	ØD1	L	L1
		SDR11	SDR17,6					
32	40	35	32	37	80	50	65	30
40	50	43	41	43	90	61	68	30
50	63	54	51	54	105	76	74	30
65	75	66	61	70	125	90	78	30
80	90	79	73	82	140	108	87	35
100	110	97	90	106	160	131	102	35
100	125	110	102	106	160	131	90	35
125	140	124	114	130	190	165	125	47
150	160	141	130	158	215	188	150	52
150	180	158	147	158	215	188	130	52
200	200	177	163	206	270	248	200	55
200	225	199	184	206	270	248	180	56
250	250	221	204	259	325	307	225	63
250	280	248	229	259	325	307	200	63
300	315	280	257	308	375	345	255	66

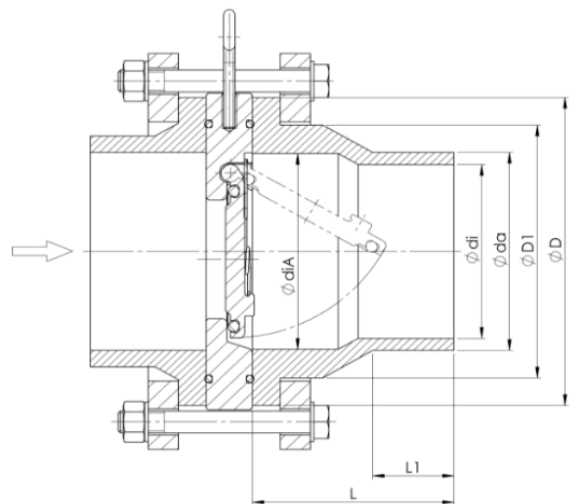

*The standard dimension ratio (SDR for short) is an indicator used to classify plastic pipes and refers to the ratio of the outer diameter of the pipe to the wall thickness. The lower the SDR number, the more pressure-resistant the pipe.

PN-allocation:

	SDR 11	SDR 17,6
PE	PN16	PN10
PP-H	PN10	PN6

Important: Due to geometric value of the SDR, the dimensions of PE und PP-H are identical but different PN values are assigned to the SDR figures of the two materials, as the strength of the PE material is significantly higher than that of PP-H. There is no generally valid correlation between the SDR figure and PN, as this always depends on the material.

Installation of flange sleeves in pipework:

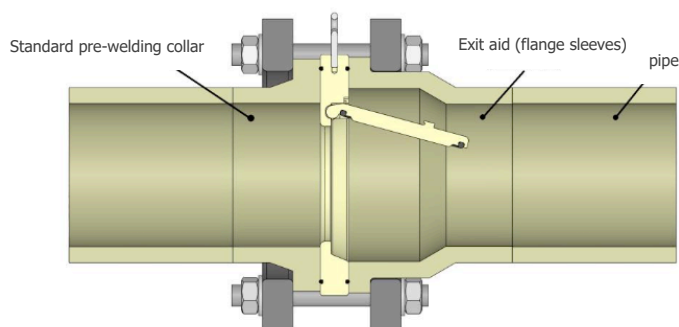

article number:

type	material	Standard dimension ratio (SDR)	diameter
BB01	00 – PP-H 01 – PE	00 – 11 01 – 17,6	06 – DN32 – d40 07 – DN40 – d50 08 – DN50 – d63 09 – DN65 – d75 10 – DN80 – d90 11 – DN100 – d110 11.1 – DN100 – d125 12 – DN125 – d140 13 – DN150 – d160 13.1 – DN150 – d180 14 – DN200 – d200 14.1 – DN200 – d225 15 – DN250 – d250 15.1 – DN250 – d280 16 – DN300 – d315

Example No:
BB01000111.1:

BB01 00 01 11.1

flange sleeve: BB01
material: PP-H
standard dimension ratio: 17,6
diameter: DN100
outer diameter ØdA: 125 mm

Image similar, subject change without notice